

Optimizing Precast Concrete Formwork Efficiency for Highrise Buildings

Hameed Shakir Al-Aasm

Al-Furat Al-Awsat Technical University, Iraq
Civil Engineering/Structural Engineering dw.hmd@atu.edu.iq

Abstract. Precast concrete is concrete that is molded and processed under the standard conditions of a high-quality factory, and then it is transported to the project site using appropriate equipment and then installed in fact, precast concrete buildings are a combination of different types of structural systems so that these systems can be combined in different ways in order to reach a useful and efficient structural system, considering that the structural connections and connecting areas of prefabricated concrete members are usually exposed to concentrated forces with high intensity, so in this article trying to explain the application of precast concrete method and the possibility of using this method in the design of existing connections between parts.

Keywords: Formwork Efficiency, Highrise Buildings, existing connections.

Introduction

Whether concrete is precast, i.e. statically reinforced or prestressed, is not always obvious. It is only when one considers the role that concrete will play in the development of structural characteristics that its precast nature becomes significant. The most obvious definition of precast concrete is that of concrete that has been prepared for casting, pouring and curing, a location that is not its final destination. The distance travelled from the casting site may be as little as a few metres, where on-site precast methods are used to avoid costly transport (or VAT in some countries), or it may be thousands of kilometres, in the case of high value-added products where manufacturing and transport costs are low.

What really distinguishes precast concrete from cast-in-situ concrete is its behaviour (stress-deformation) with respect to external (all external loads) and internal (shrinkage, temperature,) stresses. These are collectively called (actions) in the Eurocodes, and those that apply mainly to precast concrete structures are the ECO code (EN 1990-2002), the loading or (actions) code EC1 (EN 1991-1-1 2002) and the (concrete design) code EC2 (EN 1992-1-1 2004) to summarize, a precast concrete element is, by definition, a finite size element and therefore must be joined to other elements to form a complete structure.

Precast concrete includes all concrete products that are not made on site, but are manufactured in a workshop or on site next to the work. Once on site, the pre-built elements are assembled. It is produced more quickly, which allows construction to progress more quickly. As a result, it is ideal for the production of large series of elements. In general, its quality is more consistent however, its technical properties can vary depending on the dosages.

Offering the possibility of playing on its relief, its color, its texture and the state of its surface, prefabricated concrete proves to be a material of architectural expression, the dimensions of the elements to be manufactured are either standard or custom-made (production of a single piece). In the latter case, the dimensions of the elements to be manufactured must be determined precisely in advance.

Precast concrete can be used for the design and manufacture of part or all of a future building or structure in fact, it can be used as a material for the manufacture of the following elements:

1. Pre-slabs which are made of prefabricated reinforced concrete completed with concrete poured on site, they serve as formwork and reinforcement for solid concrete slabs.
2. Pre-walls which come in the form of 2 thin reinforced concrete walls which are spaced apart by metal stiffeners.
3. Formwork blocks or plug-in blocks that serve as lost formwork in concrete blocks. - Stairs (interior or exterior) that are of a higher quality than those cast in place they often consist of portions of steps and a supporting pillar that are ready to be installed.
4. Balconies that can be adapted to all types of buildings they are custom designed.

Literature Review

The beginning is represented by the manufacture of reinforced concrete elements (1945-1955) During this post-war and reconstruction period, the project managers mainly used traditional methods. However, the lack of qualified labor quickly appeared to them as a hindrance to prepare for the future, some entrepreneurs developed the beginnings of methods on which the major industrialization processes, initiated by Balency, Camus, Coignet, etc., would later be based their technique consisted of producing, in the factory, concrete elements whose rough facings had to be as finished as possible in order to avoid any subsequent intervention. The simplification of the forms, the disappearance of any superfluous addition, had to facilitate the assembly of these elements and avoid any retouching, thus making it possible to produce economical housing with a small number of repetitive parts and easy prefabrication.[1]

Then the period of rapid expansion of prefabrication (1955-1968) under pressure from public opinion, the pace of production has accelerated to meet the demand for housing this is the period of major construction projects that allow productivity gains thanks to series two competing methods are then used on a large scale ,the use of large formwork tools which allowed walls and floors to be concreted in situ: heavy prefabrication, in the factory, of flat panels, walls, facades and floors assembled in place using heavy handling equipment this was the era of "prefabrication processes" which made it possible to process orders for more than 3,000 homes in record time and to implement major industrialization programs.[2]

Then ,Market developments linked to the development of industrialization (1968-1977) during this period of strong industrialization, the creation of large complexes provoked many negative reactions from the public against the monotony and inhumanity of this type of construction we then witnessed the launch of the policy of models which was aimed at smaller operations (400 to 500 dwellings) but numerous enough to result, thanks to industrialization, in productivity gains prefabrication then changes in nature and, instead of being exclusively interested in mass production, it becomes, over time, an instrument for controlling quality, costs and deadlines.

Then the policy of construction systems and components (1977-1985), the market is increasingly moving towards very small-scale programmes leading to the "atomisation of orders" in an attempt to maintain the principle of depreciation of the tools required for mass production, the public authorities are designing a policy of construction systems based on predefined modular coordination. It was supposed to make it possible to produce buildings with great architectural freedom, but it quickly proved to be uncompetitive ,And now ,current architectural precast concrete , currently oriented towards works with elaborate characteristics, architectural precast concrete is one of the preferred tools promoting a "new architectural expression" many innovations, both in terms of the compositions implemented and the increasingly sophisticated surface treatments, allow designers to offer a very wide range of shapes, colors and textures heir to a great industrial tradition, constantly evolving, prefabricated architectural concrete, with its exceptional characteristics of resistance and plasticity, is the material of the future.[3]

About the elements used in the building :

1. Veils and plates, these are load-bearing, self-supporting, carried or suspended elements that ensure the cladding and waterproofing of the building. They are, as a general rule, one storey high and can measure up to 10 m in length. These architectural concrete panels are used both outdoors and indoors and can receive extremely varied finishes (washed, sandblasted, polished concrete, etc.) the facings and moldings are made according to the designer's wishes. They are implemented as the work progresses (case

of load-bearing elements) or are grouped together at the end of the assembly of the structural work for non-load-bearing elements. This method of operating prevents the elements from getting dirty on site and provides flexibility in terms of completion times. It is also possible to include thermal insulation between the concrete veil and the structure as a first investment, these elements may appear to be more expensive than traditional techniques (cast in place in particular). However, when maintenance and upkeep costs are included and when the overall cost is considered, the difference becomes entirely acceptable, particularly for the construction of social housing.[4]

2. Structural elements ,Elements such as beams, posts, slabs, floors, roofing, constitute or complete the load-bearing structure cast in place other elements such as balconies, loggias, passageway elements, staircases can be used to create specific spaces or volumes, partitions or circulation routes in the building.
3. Modenature elements ,They create a certain relief on the facade and can also be used as formwork for concrete cast in place this category includes elements such as columns, beams, parapet elements, cornices, genoese, bands, balustrades, bay surrounds certain elements have a specific complementary role: that of conveying runoff water to the drains and thus limiting dirt on the facings.
4. Small sized facing panels ,There are two types of elements are used: architectural concrete facing panels mechanically fixed to the structure ,hey are often used, in new construction as well as in renovation, in the tertiary sector, particularly for offices and hotels ,they can also be used for interior cladding ,these panels have a thickness of approximately 3 cm and dimensions of up to 1.2 m they are frequently combined with added thermal insulation the polished finishes offered provide great durability and reduce maintenance periods.[5]

Precast concrete inherits the advantages of classic concrete which is a solid material with several technical performances: robust, incombustible, low maintenance and thermal comfort and phonic (does not create resonance, especially if it is used as a staircase). Moreover, it also has its own advantages: [6]

1. It is perfectly waterproof.
2. It is resistant to bad weather and sudden temperature changes.
3. It is a good ally in the fight against pollution, insects and mold.
4. It saves more time not only during manufacturing, but also during installation (does not require drying time) In fact, the elements are delivered ready to be assembled.
5. It is economical because it requires less labor costs.
6. Its use is in line with compliance with environmental standards, because prefabricated concrete emits the least CO₂ compared to other masonry.

Despite its many advantages, precast concrete also has some disadvantages, as it is bulky. Thus, it is rather reserved for houses with a spacious interior, in addition, it is difficult to prime precast concrete with complex shapes, the installation of a precast concrete structure is quite complex and sometimes dangerous for reliable and safe installation, it must be entrusted to professionals.

Methodology

The height of the building is relative and buildings cannot be classified and defined according to height or number of floors the height of a building depends on social conditions and people's perceptions of the environment, so there is no single standard for defining tall buildings ,but some regulations are forced to provide criteria to separate tall buildings from short buildings; Also, according to CTBUH regulations, buildings higher than 14 floors Or 50 meters high as tall buildings (Tall Buildings), buildings between 300 and 600 meters high as (Height) and buildings taller than 600 meters as super buildings (Supertall or Magatall Buildings) Buildings) are introduced 181 but from the point of view of engineering, a building can be considered high when its height causes the lateral forces caused by earthquakes and wind to have significant effects on the design of the structure .[7]

The process of optimizing precast concrete formwork for high-rise buildings involves a comprehensive approach to improve both the quality and efficiency of formwork systems while maintaining safety, cost-effectiveness, and adherence to project timelines, the methodology for achieving this includes several key phases: design selection of materials, automation, and continuous monitoring and feedback, before any formwork is installed, the first step involves thorough planning and analysis of the high-rise project. During this phase, the structural design of the building is reviewed in order to determine the optimal formwork solution, this includes:

1. Load-bearing Requirements: Understanding the loads the formwork will need to withstand is critical for selecting appropriate materials.
2. Modular Formwork Design: A modular system allows for reusability, leading to significant time and cost savings. The design of the formwork should be adaptable to different types of walls, slabs, and columns.
3. Integration with Overall Construction Process: The formwork design should be integrated with the building's construction schedule, facilitating smoother transitions between stages of the building process.[8]

Assemblies, also called connections, are used to mechanically connect elements to each other and to the structure, the general organization of the connections and their choice must be the subject of a mechanical study taking into account the different phases of construction and use of the building, With reference to standard P 10-210 (DTU 22.1), assemblies are classified into four types.

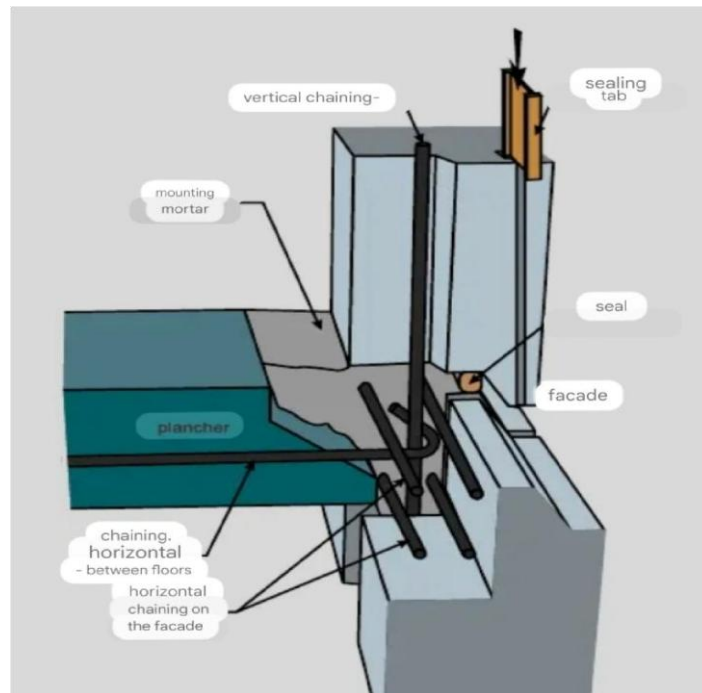

Type 1, Figure (1): continuous mortar joints, they are used to produce simple supports, their use is limited to assemblies that do not require the absorption of significant shear forces.

Figure (1) Type 1: continuous mortar joints

Type 2, Figure (2) : continuous concrete connections without pending reinforcement they allow the shear forces developing orthogonally to two juxtaposed elements to be taken up; notches can also be made to provide reinforcement for the shear exerted along the longitudinal axis of the connection. [9]

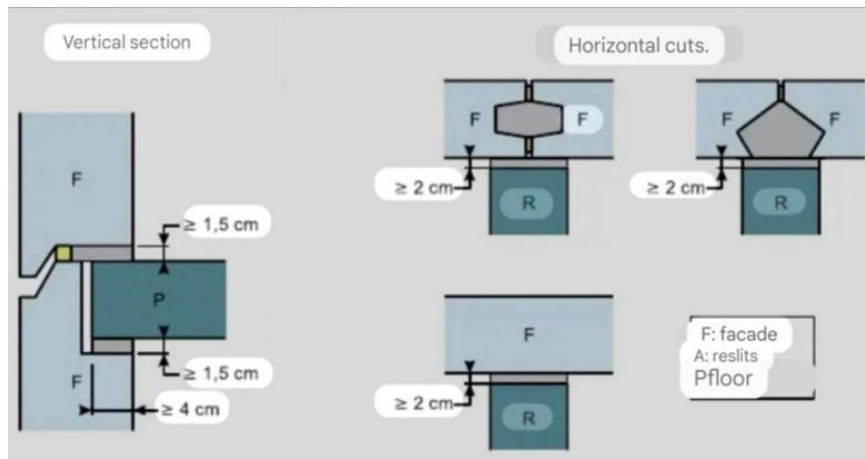

Figure 2 Type 2: continuous concrete connections without pending reinforcement

Type 3: continuous concrete connections with reinforcements pending

They ensure the transmission of forces from one element to another and are also used to create chains, their cross section can be used as a shear lock positioned between two adjoining sequences of walls, Devices such as notches or metal connecting loops can be used to reinforce the shear resistance. Connecting loops can also be used to connect two orthogonal sequences of panels and thus create a restraint (i.e. the non-displacement of a panel orthogonally to its plane).

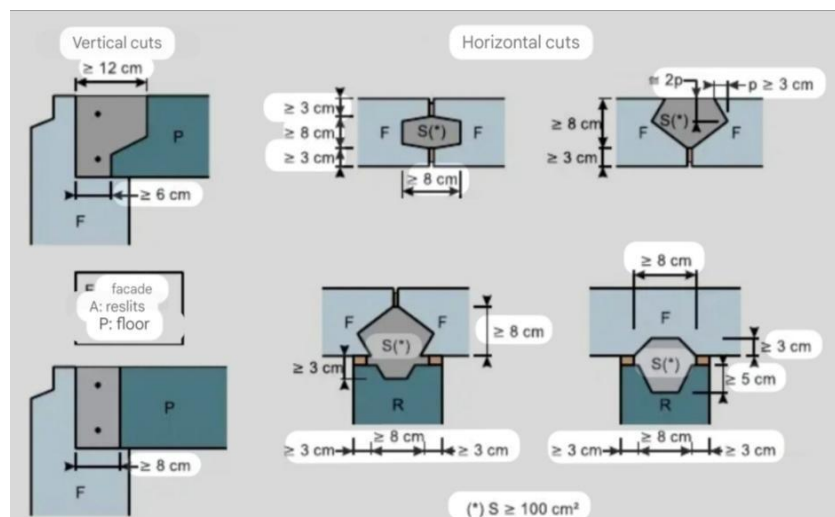

Figure 3 Type 3. continuous concrete connections with reinforcements pending

Type 4, Figure (4): point connections

These are concreted, bolted, broached or welded connections which allow the dry assembly of the elements (i.e. without, or with little concrete pouring), they are frequently used because of their simplicity of implementation depending on their constitution, they can take up shear. [10]

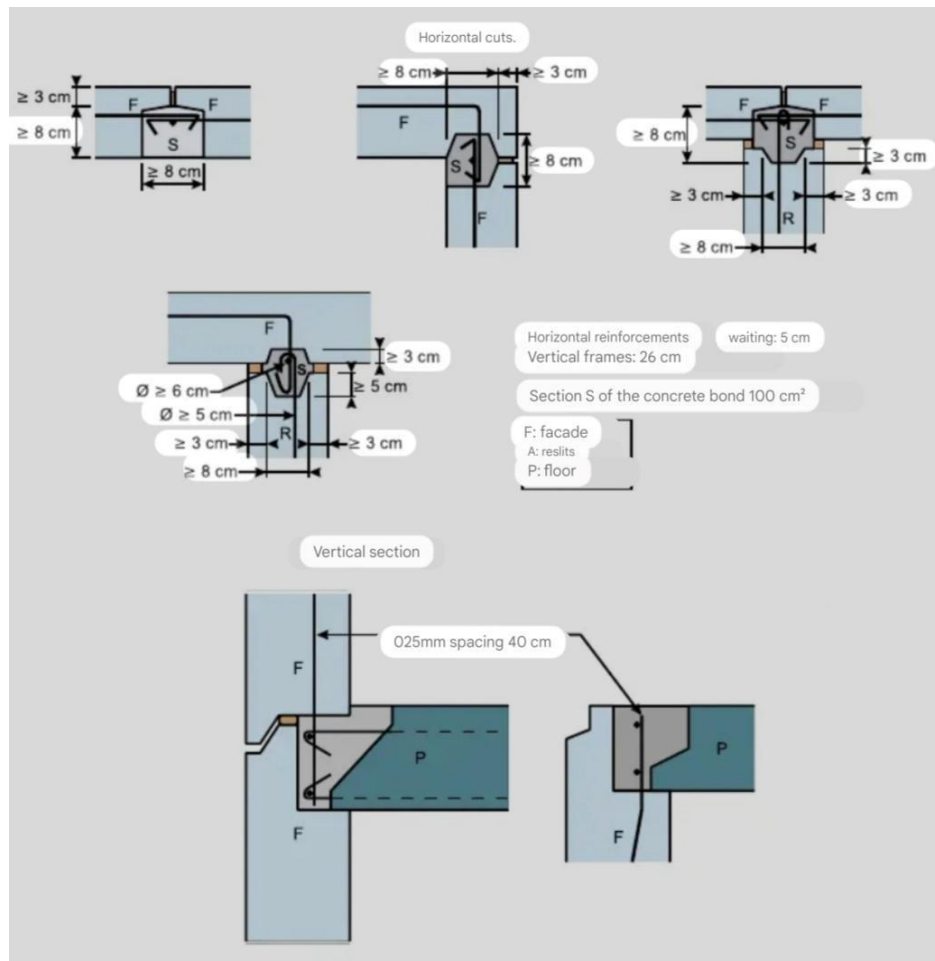

Figure 4 Type 4. point connections

Concrete point connections are also used to create chain continuities, Non-load-bearing elements most often use specific point connections (hangers) to attach themselves to the structure of the building. [11]

The choice and spacing of the links are determined according to stability calculations of the structure, the dimension of the elements of the mechanical behavior of the elements (load-bearing or not); of the destination of the work.

The possible assemblies between two elements are indicated in accordance with standard P 10-210 (DTU 22.1) as shown in figures (5-a),(5-b). For example, 3.4 indicates that the possible connection types for this case are types 3 or 4, Figure (6). When the operation of the structure allows it, it is preferable to use, for concrete connections, point assemblies in order to avoid a risk of soiling the facings during implementation.[12]

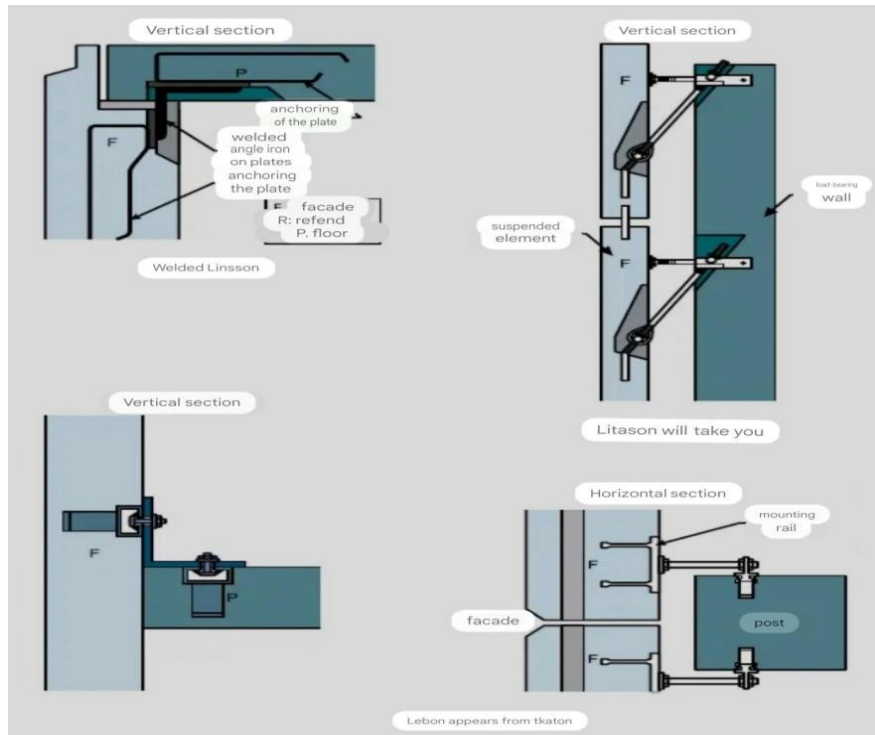

Figure 5-a. Assemblies between two elements

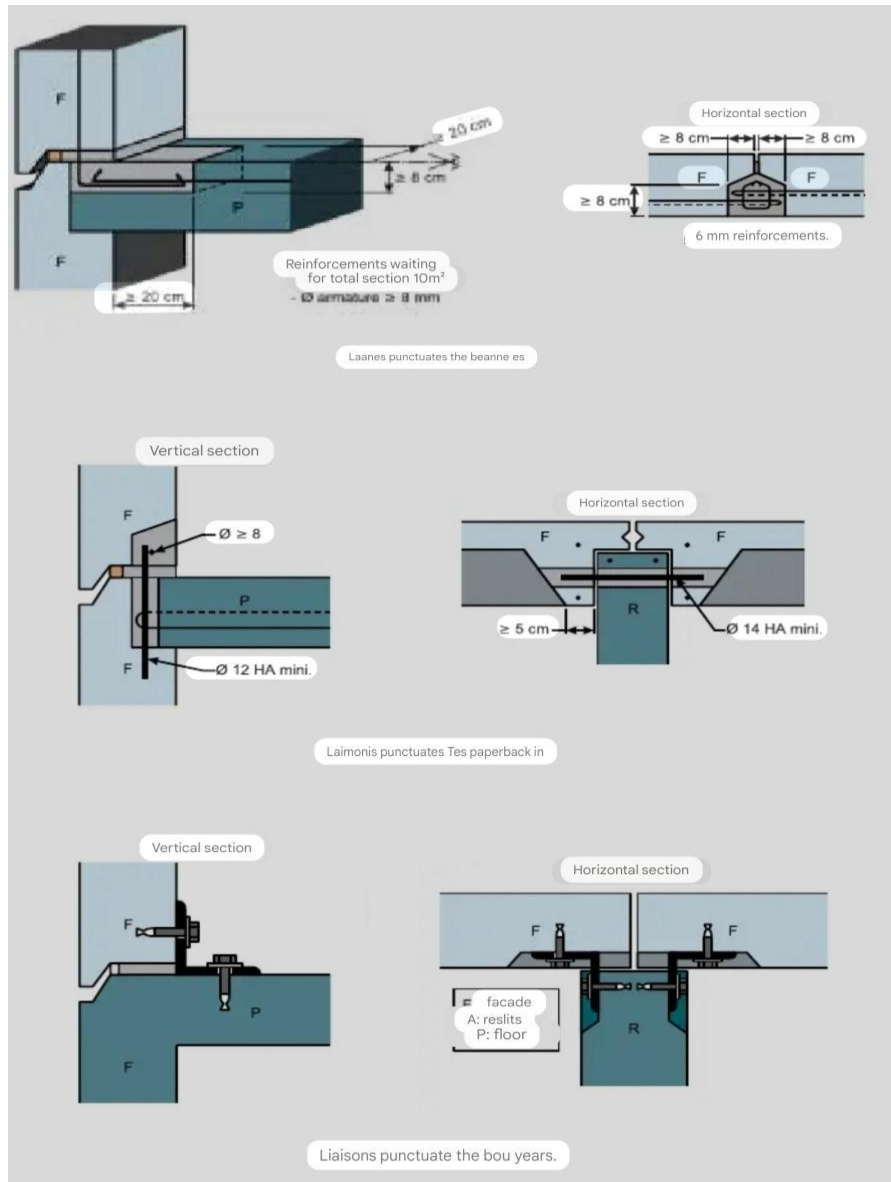

Figure 5-b. Assemblies between two elements

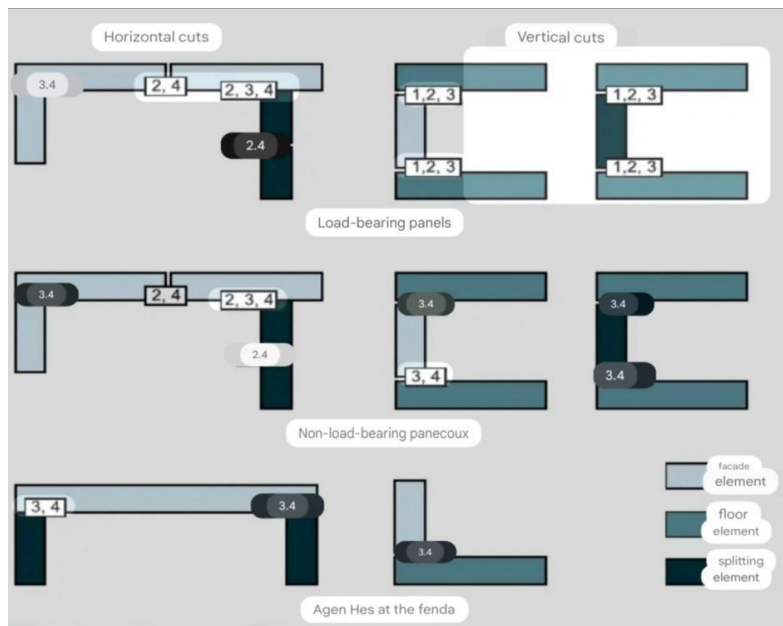

Figure 6. Possible connection types

Results and Discussion

In addition to the main advantages of prefabricated concrete structures, such as reducing the execution time of manufacturing quality and standard parts under factory conditions, economic and cost-effective use of materials and the possibility of using them repeatedly, the molding system, the possibility of using larger parts and less need for The skilled workers of the mentioned structures also have limitations, including the size of the parts, less variation in the position of the window openings, predicting the details of the connections before implementation, and the limited space of the parts in the workshop. Depending on the type of prefabricated structure, different design methods can be used. One of these methods is the equivalent truss method. In general, the equivalent truss method is considered one of the appropriate tools for the purpose of designing connection areas and also checking whether the equilibrium conditions in the final limit state are satisfactory or not. This method usually determines the force flow along the structural connection. Therefore, it will help the designer to better understand the connection behavior.[13]

In fact, prefabricated concrete buildings are a combination of different types of structural systems, so that these systems can be combined in different ways to achieve a useful and efficient structural system.

Precast concrete includes:

1. Beam and column systems, beam elements, column elements, connections
2. Roof and floor system, roof elements, floor elements, fittings)
3. Load-bearing wall system, connecting wall elements)
4. Facade building systems, facade elements, connections)

In general, it is not possible to be satisfied with the above options because engineers and architects consider other elements in the construction of such buildings, among which arches and rigid portal frames can be mentioned, building facades are often load-bearing and provide lateral stability, but they can also be considered non-load-bearing. Among other prefabricated concrete systems, the following two can be mentioned :

1. Frame systems, frame elements, connections.
2. Cellular systems, cellular elements, junctions.

1. Beam and column systems

In general, although in beam and column systems, the beams are considered more like inclined roof beams, but in fact they are a combination of beams and columns. In the shape mode the height of the column is considered to be more than the height of a floor, In Figure 1a It shows the skeletal frame system. The required connections in these systems are (Arrow to column, arrow by arrow, Column by column, Column to foundation) [14]

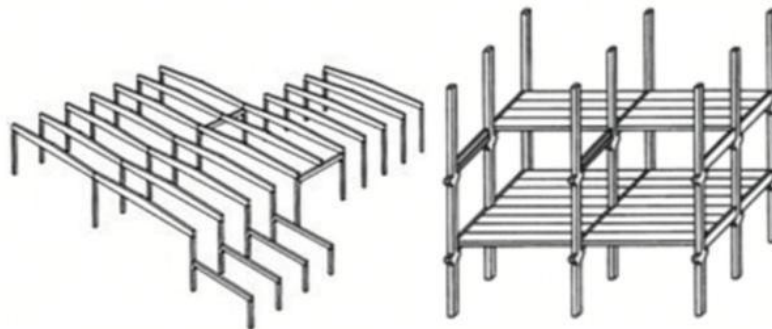

Figure 7. column beam systems (a) one-story columns (b) multi-story columns

2. Ceiling and floor systems

The main task of roof and floor systems is to transfer the vertical load to structural elements resistant to vertical load apart from these prefabricated roofs and floors are usually the main parts of the structural stabilization system in order to transfer horizontal loads with the help of aperture are considered. (FIB Guide)

Among the common flooring systems, we can mention hollow flooring and flooring with

double shield ,double shields are usually used in ceiling systems,the connections related to these systems are (Slab-to-slab connection in internal longitudinal joints ,Connecting the slab to the edge of the member at the longitudinal edge ,Slab-to-slab connection in the inner support ,Connecting the slab to the end support)[15]

The elements of the flooring system do not resist the loads separately, but the degree of interaction between the adjacent elements or members is desirable. In order to achieve the transverse distribution of load effects in the conditions of applying concentrated loads and also in order to prevent the change of vertical locations in the longitudinal joints of the floor joints, they must have shear key function to make sure that the interaction between the adjacent members is in optimal conditions.

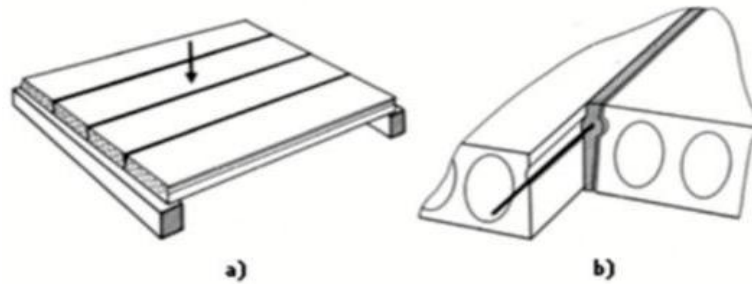

Figure 8. Interaction and transverse distribution of load effects
(a) Width load distribution (b) Detail of seam along with longitudinal shear key

Figure (8) demonstrate the Interaction and transverse distribution of load effects of adjacent prefabricated hollow members obtained by shear transfer in the direction of longitudinal seams: (a) Width load distribution and (b) Detail of seam along with longitudinal shear key in composite flat flooring, which is called Half-slabs are also called prefabricated concrete slabs for the part that is concreted in place as a mold and remains completely in the composite part of the floor ,composite performance depends on how shear is transferred in the horizontal joint between the precast parts and the cast-in-place concrete section.

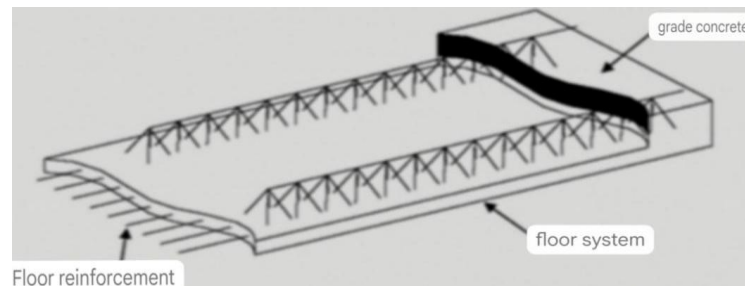

Figure 9. Composite flooring system

3. Wall systems

The main types of precast concrete wall systems are shown in the figure below. Walls are usually classified into load-bearing and non-load-bearing. Bearing walls are used to bear the load of members such as floors, ceilings or beams. Examples of non-load-bearing walls are also shown in Figure (10).The connections used in these walls are (Wall-to-wall connection in internal and external vertical seams ,Wall-to-wall connection in internal and external horizontal joints ,Connecting the wall to the foundation ,load-bearing transverse walls).[16]

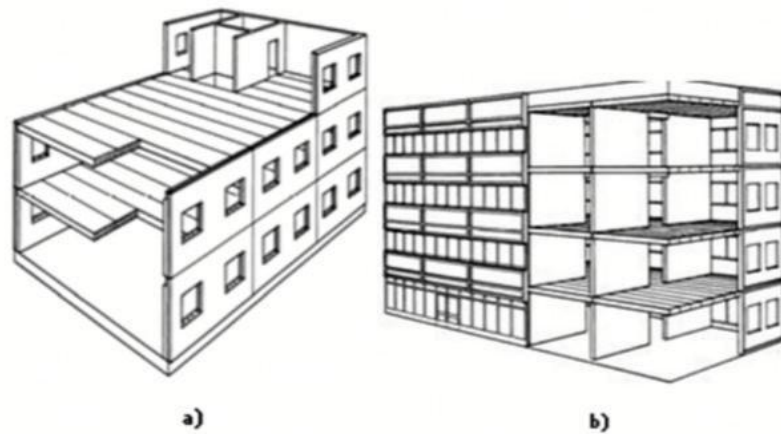

Figure 10. (a) facade load-bearing walls (b) load-bearing transverse walls connections in non-load-bearing wall systems

Figure (10) show examples of load-bearing walls system: (a) facade load-bearing walls (b) load-bearing transverse walls connections in non-load-bearing wall systems are usually connecting the facade to the beam. They are usually rarely attached to the column.

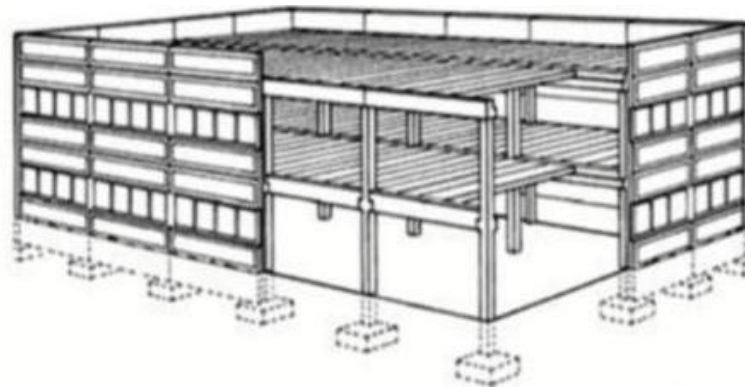

Figure 11. Non-load-bearing walls

Usually, non-load-bearing walls are designed to bear their own load, so the joints embedded in the horizontal joints must bear the weight of the walls at the upper level of the wall, so the non-load-bearing walls may be connected to their adjacent load-bearing system so that the dead weight of each of the wall parts is supported by the main system is tolerated.[17]. Prefabricated walls can be considered as a part of the structural stabilization system in order to resist horizontal loads , In this situation, the prefabricated wall should behave like a building block Figure (12) therefore, the resulting interaction in the wall should be controlled in a proper way by using structural connections that can withstand tensile and compressive shear forces. In general, the wall system in prefabricated concrete structures is divided into two main categories: transverse wall system and floor longitudinal wall system. In the system of transverse walls, the load-bearing walls are placed in perpendicular stretches along the longitudinal length of the building, and in addition to bearing the gravity loads that are transferred to them from the one-way slabs, the resistance They provide the building against the lateral forces of the earthquake in the transverse direction. In the system of longitudinal walls, the main load-bearing walls are placed parallel to the longitudinal direction of the building, and in addition to bearing the gravity loads transferred by the one-way slabs, the task of providing the resistance of the building against the earthquake forces.

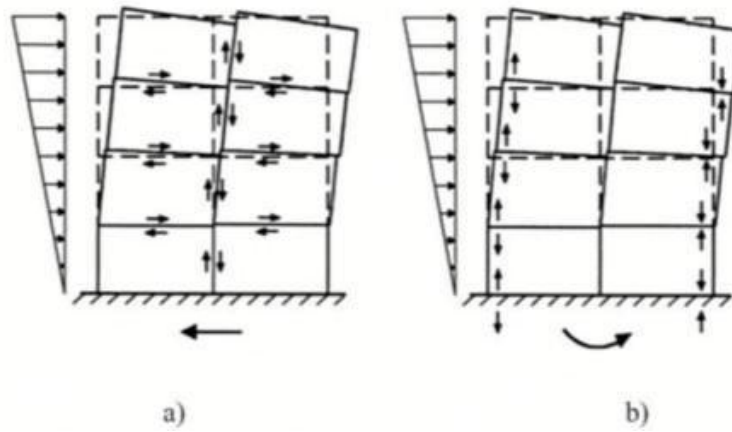

Figure 12. In-plane performance of prefabricated wall (a) shear forces (b) compressive and tensile forces

4. Time frame system

The prefabricated concrete moment frame system is usually used in portal or skeleton systems where the role of the frame is decisive in providing the stability of the system. This is achieved through the combination of H-shaped, L-shaped members or portal frames, etc., using homogeneous connections at the intersection of beams and columns. Members are usually connected in parts where the turning point of the connection does not require bending resistance, alternatively, connections between beams and columns may be designed to achieve an acceptable resisting anchor capacity.

5. Cellular or hollow system

Hollow cellular precast concrete system) are usually composed of closed or open hollow members with U or L-shaped sections. Therefore, using cellular members for a specific part of the structure is common and normal

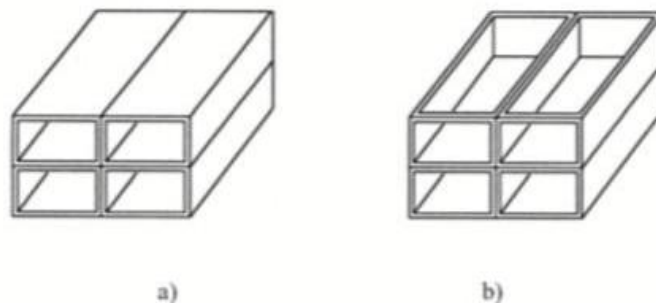

Figure 13. (a) closed cell members (b) open cell members with U-shaped

Structural connections and connection areas of precast concrete members are usually exposed to concentrated forces of high intensity when these forces are transmitted along the joint and thus the adjacent members are distributed along the section creating a deviation in the forces, for example, changing the direction of the forces and even the distribution of stresses causes the creation of transverse stresses with a large amount if the tensile strength of concrete increases, cracks will appear in these areas, therefore, if you do not pay enough attention to this cracks increase the speed of the member's injury process and may cause breakage in the support area Sometimes it can limit the connection capacity.

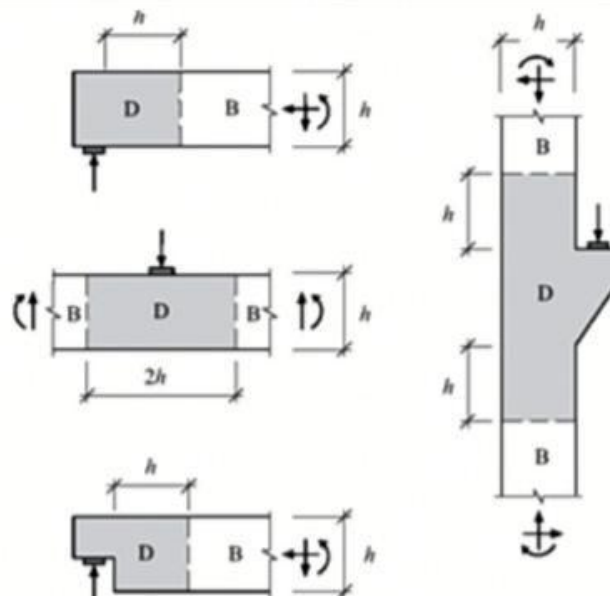

Figure 14.

At this stage, the prefabricated concrete member is divided into two areas B and D. In area B, Bertoli's hypothesis related to the linear distribution of strain along the section can be applied at this stage, the sections can be subjected to bending anchor with or without axial force based on the traditional methods used in reinforced or prestressed concrete sections have analyzed and designed, in the area, the strain distribution can be analyzed and designed using the linear mode method or other methods, because of the geometric and static discontinuities in the structural connections, the connection areas should be considered as discontinuous areas in fact, the junction area A precast concrete member may be considered as a discontinuous area.[18]

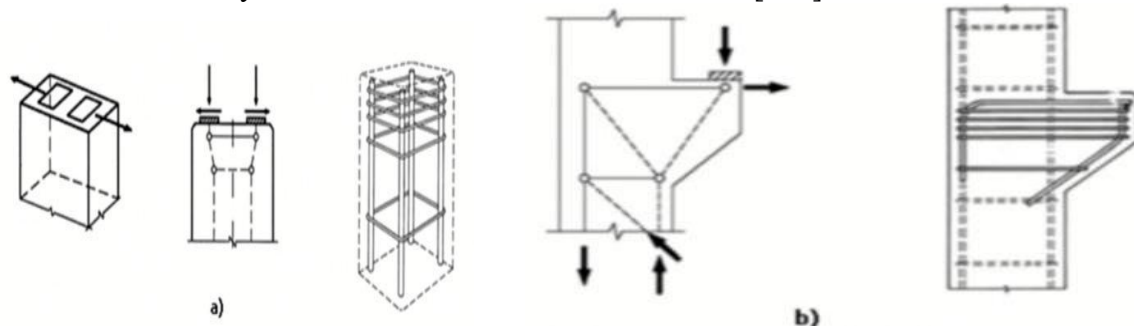

Figure 15. (a) Column head design detail (b) Column front design detail

The equivalent truss method is based on the theory of plasticity or malleability in the conditions where the critical areas of connections have sufficient plastic deformation capacity, it will be easier to understand its behavior the designer must choose the equivalent truss model in such a way that the stress area in the cracked reinforced concrete is simulated and maintains its equilibrium under the design load conditions in most cases the limits of the permissible deformations are based on the assumption of the bending and ductile response of the prefabricated member. Connection areas in precast concrete members are usually defined as non-continuous areas. The equivalent truss method can be used to study the flow of forces, which can itself be considered as the basis of member design put to use (a) Column head design detail (b) Column front design detail, the constituent members of the equivalent truss system include ties, braces, and knots, until the selected stress area under the applied load is in equilibrium and no critical area is under excessive stress. In this case, the stress area can be checked theoretically was Therefore, the actual stress area of the structure under the applied loads may be different. [19]. If the concrete is exposed to small loads, it remains

uncracked. In this condition, the reinforcement will have a small effect on its behavior, at this stage, the concrete has a linear elastic response and the behavior of the connection area should be analyzed be linear and based on the theory of elasticity for homogeneous materials, therefore, with the increase in load, the possibility of concrete cracking also increases. In this condition, the reinforcements placed along the cracks play a major role in the behavior of concrete. The characteristic of hardness will be different before and after cracking, the actual area of stress is also the amount of actual hardness, which is also affected by the arrangement of reinforcements and the general state of cracking, It will depend. Therefore, different arrangements of reinforcements will create different stress areas. In the conditions of increased load, cracking also increases and as a result causes continuous changes in hardness and corresponding stress, which is called stress redistribution due to cracking in the conditions of applying loads with large amounts, the critical points of the connections will be under tension, both the concrete that is under pressure and the steel have plastic behavior in high tractions due to the presence of this plastic behavior in some critical points, the hardness of the connection area changes again and It causes a change in the stress area. When the amount of incoming load increases more and more, the stresses in these critical points will not increase more, but by the amount the considered resistance is limited by the designer , this change in the shape of the stress zone is called redistribution of plastic stress when redistributing plastic, the plastic deformation capacity of the critical areas needs to be reasonable in the theory of plasticity, it is assumed that materials have plastic behavior and are ideal with the capacity to change the shape of the final plastic ,at this stage, there will be a mismatch between the presented theory and the truth ,reinforced concrete has a limited plastic deformation capacity investigating the phenomenon of plastic redistribution itself requires investigation and sufficient knowledge about plastic deformations in addition, the plastic deformation capacity in the connection areas in the designs is very limited as a result, the designer must choose equivalent truss models should be careful to avoid choosing models with high plastic redistribution values ,Therefore, it is recommended that much of the elastic stress area calculated by linear analysis Do not distance yourself.

Conclusion

In conclusion, improving the efficiency of precast concrete formwork in high-rise buildings is a key step towards progress in the construction industry. By using innovative techniques and advanced technology, the costs and time required to implement projects can be reduced without compromising on quality and safety. Improving these processes requires continuous collaboration between engineers, contractors and manufacturers to ensure best practices and design updates are applied in line with the needs of future projects. Investing in improving precast concrete formwork represents a strategic step towards building more sustainable and efficient projects, contributing to the development of the construction industry and meeting the requirements of the modern era. In general, choosing the right structural system in prefabricated concrete structures is very important for this purpose, in order to obtain better structural behavior, hybrid structural systems can also be used due to the fact that all structures are subjected to various loads and forces, it is important for the designer to understand all types of forces, including tensile, compressive and shear, by the designer one of the best commonly used methods is the equivalent truss method in this method, the member subjected to tensile force is called Tie and the member under compression is called Strut, considering that this method is based on the theory of plasticity, therefore, the method of choosing the equivalent truss model should be done in such a way that the stress area in the reinforced concrete is cracked be simulated.

References

- [1] R. Richard, "Five degrees of industrialized building production," *New Perspective in Industrialization in Construction-a State of the Art Report*, 2020, pp. 15-27.
- [2] M. Hook and L. Stehn, "Connecting Lean Construction to Pre-fabrication Complexity in Swedish Volume Element Housing," in *13th International Group for Lean Construction Conference: Proceedings*, International Group on Lean Construction, 2022, p. 317.

- [3] K. Zitouni, "Effect of recycled aggregates on the development of the microstructure of self-compacting concrete," Construction, Transport and Environmental Protection Laboratory (LCTPE), Abdelhamid Ibn Badis University, Mostaganem, Algeria, 2021, p. 199.
- [4] D. V. Dieryck and P. Van Itterbeeck, "Prescribing a self-compacting concrete," Concrete Technology Laboratory, CSTC and Structures Laboratory, CSTC, 2021, p. 31. Available: <https://www.cstc.be/homepage/download.cfm?lang=fr&dtype-publ&doc=cstearonline>
- [5] M. Benhouana, B. Nezergui, and S. Boudraa, "Valorization of recycled aggregates in the formulation of a self-compacting concrete," in SBEIDCO 1st International Conference of Sustainable Built Environment Infrastructure in Developing Countries, ENSET Oran, Algeria, Oct. 12-14, 2019, p. 256.
- [6] V. Corinaldesi and G. Moriconi, "Self-compacting concrete: A great opportunity for recycling materials," in International RILEM Conference on the Use of Recycled Materials in Building and Structures, Nov. 8-11, 2024, Spain, p. 532.
- [7] Z. J. Grdic, A. Topilic-Curcic, G. Despotovic, and N. S. Ristic, "Properties of self-compacting concrete prepared with coarse recycled concrete aggregate," Construction and Building Materials, 2020, p. 90.
- [8] Debbih, "Formulation of a self-placing concrete based on recycled aggregates, dairy and natural pozzolan," Master's thesis, April 2024, p. 172.
- [9] K. Falek, "Study of mechanical and rheological behavior of a concrete based on recycled aggregates," Doctoral thesis, 2023, p. 281.
- [10] K. Durbani and N. Bouhanichi, "Permeable concrete based on recycled aggregates: from formulation to behavior," 2023, p. 50.
- [11] G. Fathifazl, A. Abbas, A. Razaqpur, O. B. Isgor, B. Fournier, and S. Foo, "New mixture proportioning method for concrete made with coarse recycled concrete aggregate," Journal of Materials in Civil Engineering, 2022, p. 25.
- [12] M. Etxeberria, E. Vazquez, A. Mari, and M. Barra, "Influence of amount of recycled coarse aggregates and production process on properties of recycled aggregate concrete," Cement and Concrete Research, 2023, p. 54.
- [13] V. W. Y. Tam, X. F. Gao, and C. M. Tam, "Microstructural analysis of recycled aggregate concrete produced from two-stage mixing approach," Cement and Concrete Research, 2024, p. 31.
- [14] M. Messiad and A. Bourtal, "Characterization using non-destructive testing (NDT) and Direct test of a self-compacting concrete (SCC) based on local materials (effect of the nature of the sand)," Master's thesis, University of Mohamed Boudiaf M'sila, 2022, p. 192.
- [15] M. Behim and T. Ali Boucetta, "Effect of micronized additions on the flow of self-compacting concrete (blast furnace slag, limestone filler and glass powder)," ENSET Oran, Algeria, Oct. 2023, p. 48.
- [16] M. Omar, "Durability of cementitious materials modeling the influence of physicochemical balances on the microstructure and residual mechanical properties," Doctoral thesis, Ecole Normale Supérieure de Cachan, France, 2021, p. 20.
- [17] H. Hebhouh and M. Belachia, "Marble wastes and introduction into the hydraulic concrete," Research report, Nature Technologie, 2023, p. 111.
- [18] F. Hamza, "Experimental study of the rheology and behavior of self-compacting concretes: influence of fine limestone and plant fibers," Doctoral thesis in Civil Engineering, Cergy-Pontoise University, 2021, p. 152.
- [19] H. Fares, "Mechanical and physicochemical properties of self-compacting concretes exposed to high temperatures," Doctoral thesis, University of Cergy Pontoise, 2023, p. 66.